



EDGE/GPRS/GSM SINGLE-CHIP MULTIMEDIA BASEBAND PROCESSOR

FEATURES

- **General Characteristics**
 - Single-chip, mixed-signal, 302-pin FBGA package (10 mm × 10 mm)
 - GSM voice handset capabilities: FR/EFR/HR/AMR
 - GSM850, E-GSM900, GSM1800, and GSM1900 bands
 - EDGE/GPRS mobile Class B (multislot Class 12)
 - All data modes for EDGE and GPRS
 - ARM926EJ™ core at 156 MHz with I/D caches of 8 KB
 - External NAND, NOR, SRAM, SDRAM at 1.8V or 3.0V
 - ARM® boot options: ROM/UART/SRAM/NAND
- **Display and Camera**
 - 2-megapixel camera interface
 - QCIF encode at 15 fps or decode at 30 fps
 - DMA controller with four simultaneous channels
 - Video output interface to TV encoder
 - Serial or parallel LCD interface for 262K color at 1.8V
 - 2D graphics, MPEG-4 SAD, and DCT accelerators
- **Enhanced Interfaces**
 - Bluetooth® interface via UART + audio PCM; WiFi® via SDIO
 - PCMCIA, SDIO, IrDA, and 4-bit SD/MMC interfaces
 - USB 2.0 full-speed (12 Mbps); three UART at 3.68 Mbps
 - Direct SIM connections at both 3.0V and 1.8V (no LDO required)
- **Improved Audio**
 - SAIC for voice + data, echo canceling, noise suppression, and internal CTM
 - Proprietary M-Stream technology improves handset reception and voice quality
 - 11-kHz voice audio output bandwidth
 - Two high-output speaker drivers (main and headphone)
 - Interface to external stereo DAC through I2S for MP3 music
 - GSM voice handset capabilities: FR/EFR/HR/AMR codecs
 - Integrated up to 64-tone MIDI polyringer at 22 kHz

SUMMARY OF BENEFITS

- **Comprehensive EDGE/GPRS/GSM System Design**
 - Release 99 EDGE/GPRS/GSM protocol stack
 - Proven reference designs for bar and flip-type handsets
 - Color display support (up to 262K colors) for two panels
 - ROM-less radio design for low-cost smartphones
 - ARM RealView® and TeakLite® debugging environments
- **Upgraded ARM Memory Bus Interface (eight-chip selects)**
 - ARM926EJ core speed increased to 156 MHz
 - Various combo or discrete memories at 1.8V or 3.0V
 - NOR flash: 256 Mb with 52-MHz burst read, page modes
 - NAND flash: 4 Gb
 - SRAM: 128 Mb with 52-MHz burst read and write
 - SDRAM: 256 Mb at 78-MHz clock
- **Integration**
 - Integrated 64-tone MIDI polyringer eliminates costly PCB component. Allows mixing of polyringer and voice audio
 - SIM signals connect directly to the BCM2133, providing a 3.0V/1.8V switching interface with only passive components
 - Low-power consumption due to extensive use of accelerators for compute-intensive functions

APPLICATIONS

- **Entry to high tier EDGE feature phones**
- **Embedded EDGE modems**
- **2G baseband in WEDGE design utilizing BCM2141 WCDMA coprocessor**

System Block Diagram

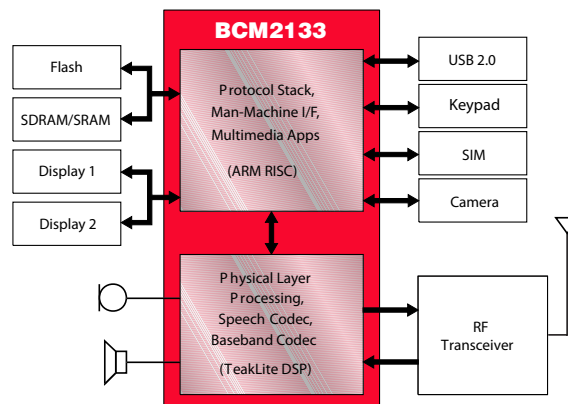

OVERVIEW

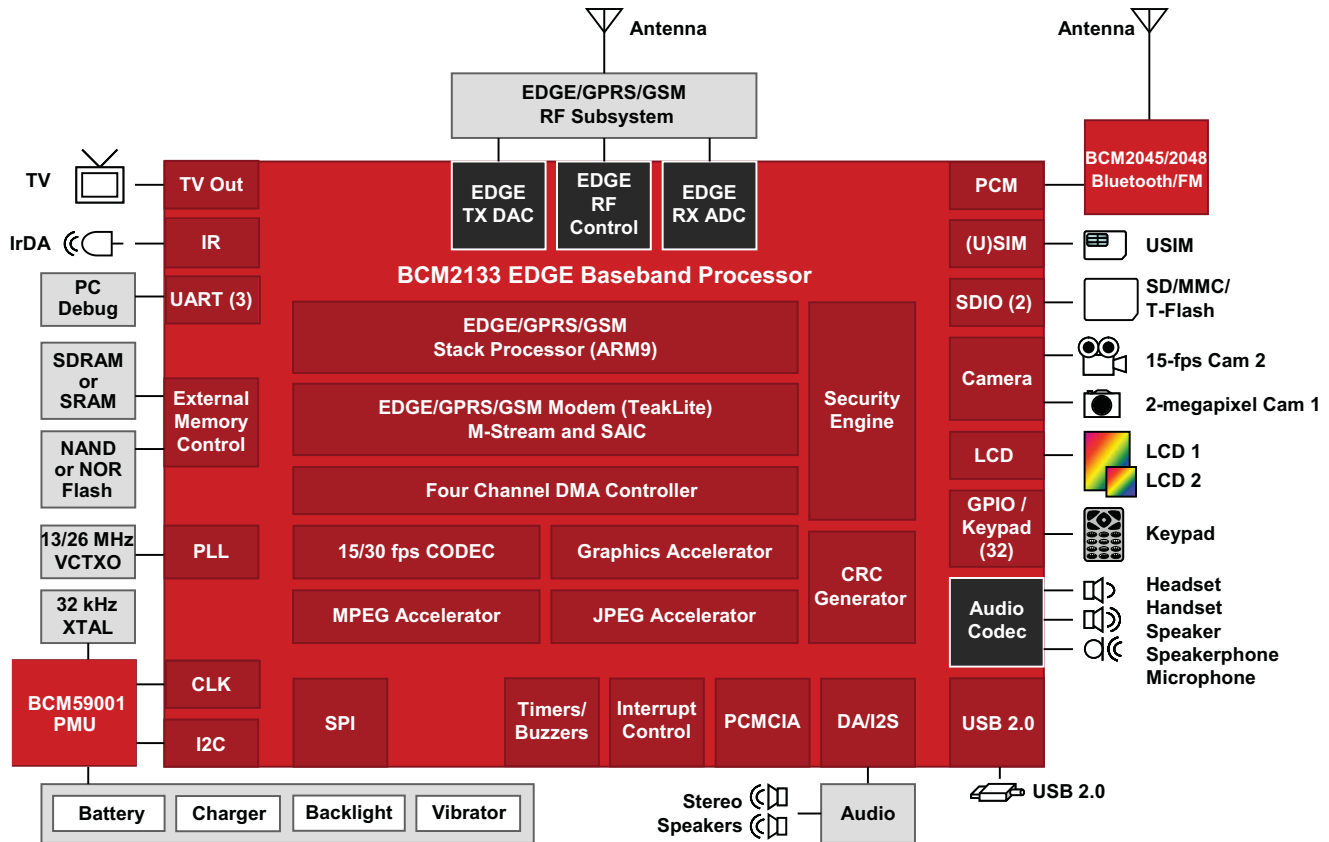

Functional Block Diagram

Overview

The BCM2133 EDGE/GPRS/GSM baseband processor offers a small footprint, baseband solution for the development of broadband EDGE feature phones, smartphones, PC cards, and embedded modules.

The EDGE Class 12 capability enables over-the-air data speeds up to 200 Kbps to achieve broadband-like connectivity and supports applications like video and music downloads.

Interface functions and drivers are integrated to enable auxiliary components, such as handset and headset microphones, handsets, headsets, and speakerphone speakers (up to 400 mW into 8Ω) and 3.0V/1.8V switching SIM to connect directly to the chip.

The memory interfaces can run at either 1.8V or 3.0V to allow the use of new low-power devices.

Separate parallel LCD and ARM memory busses allow the user interface to be updated without impacting the real-time radio operations.

Broadcom[®], the pulse logo, **Connecting everything**[®], and the Connecting everything logo are among the trademarks of Broadcom Corporation and/or its affiliates in the United States, certain other countries and/or the EU. Bluetooth[®] is a trademark of the Bluetooth SIG. Any other trademarks or trade names mentioned are the property of their respective owners.

Connecting
everything[®]

Interfaces

Compared to previous chips, the BCM2133 has improved interfaces and radio control capabilities to allow higher-end handsets to be made at lower cost.

Interfaces:

- SDIO interface at 100 Mbps
- 4-bit SD/MMC interface at 100 Mbps
- Three UARTs at 3.68 Mbps
- 3-wire RF control and SPI interfaces
- PCMCIA interface to PC at 921.2 Kbps

Radio Control Capabilities:

- GMSK/8PSK mixed-multislot transmission
- SAIC and M-Stream algorithms for better RF performance
- Two DACs for separate GMSK and 8PSK power control

BROADCOM CORPORATION
16215 Alton Parkway, P.O. Box 57013
Irvine, California 92619-7013

© 2006 by BROADCOM CORPORATION. All rights reserved.

2133-PB07-D1 11/30/06



Phone: 949-450-8700
Fax: 949-450-8710
E-mail: info@broadcom.com
Web: www.broadcom.com