



MOBILE POWER MANAGEMENT UNIT

FEATURES

- Two multimode 300-mA switching regulators with high efficiency over wide-load range
 - 93% peak efficiency @ 200 mA load
 - 83% efficiency at 1 mA load
 - Programmable output voltages 0.9V–2.5V
- 11 LDOs with programmable output voltage
 - RF and analog LDOs with < 30- μ V noise and typ 70-dB PSRR
 - Ultra low dropout of 100 mV at 200 mA
 - Ultra low-power ECO mode for sleep cycle
- CC/CV USB/wall adapter charger with auto-detection
- Battery monitoring with highly accurate coulomb counter-based fuel-gauge
- Programmable CC/CV backup battery charger
- Real-time clock with programmable alarm
- Accessory detection
- I²C-compatible serial interface
- Low-profile 48-pin, 6 mm x 6 mm PQFN package

SUMMARY OF BENEFITS

- High level of integration reduces the power and battery management bill of materials.
- Multimode buck switchers offer best-in-class efficiency.
- Switchers high-operating PWM frequency enables low-profile, small footprint magnetic components selection.
- Output voltage programming of all switchers and LDOs offers flexibility of use.
- Extended system active/idle mode operations time is achieved due to high-efficiency, low-quiescent current and ECO mode operation.
- Charger input voltage up to 20V enables the adoption of inexpensive AC/DC adapters.
- Higher reliability and flexibility of system operation with programmable start-up sequencing.
- High-performance, noise-free linear charger with fast/trickle charge modes.
- Highly accurate fuel gauge provides true battery condition reporting.

APPLICATIONS

- GSM/GPRS/EDGE/WEDGE/HSDPA/CDMA4 mobile handsets
- Handhelds, PDA, Smart Phones, PMP, MP3, Gaming, GPS, and other portable applications
- Total system solution with BCM2133 or BCM2133/BCM2141, BCM2124, BCM2141 and BCM2152 Cellular basebands

Mobile Handset Power and Battery Management Platform

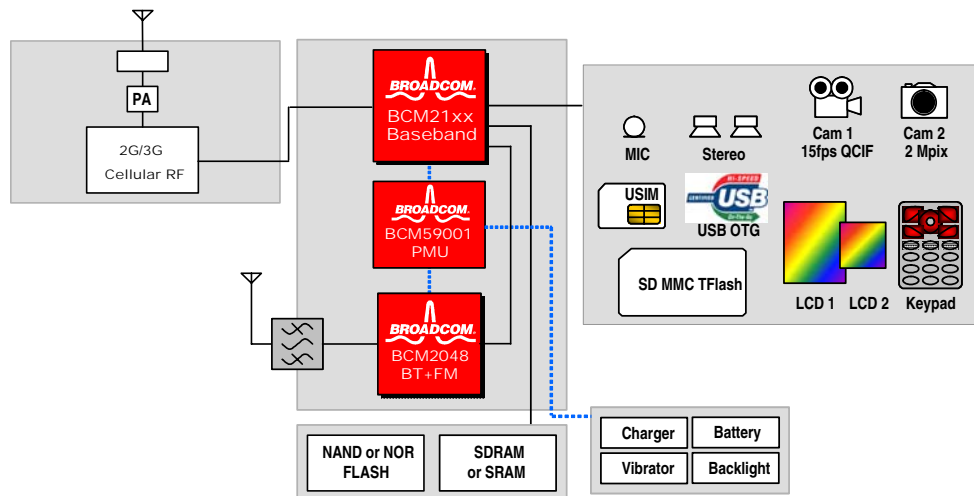

OVERVIEW

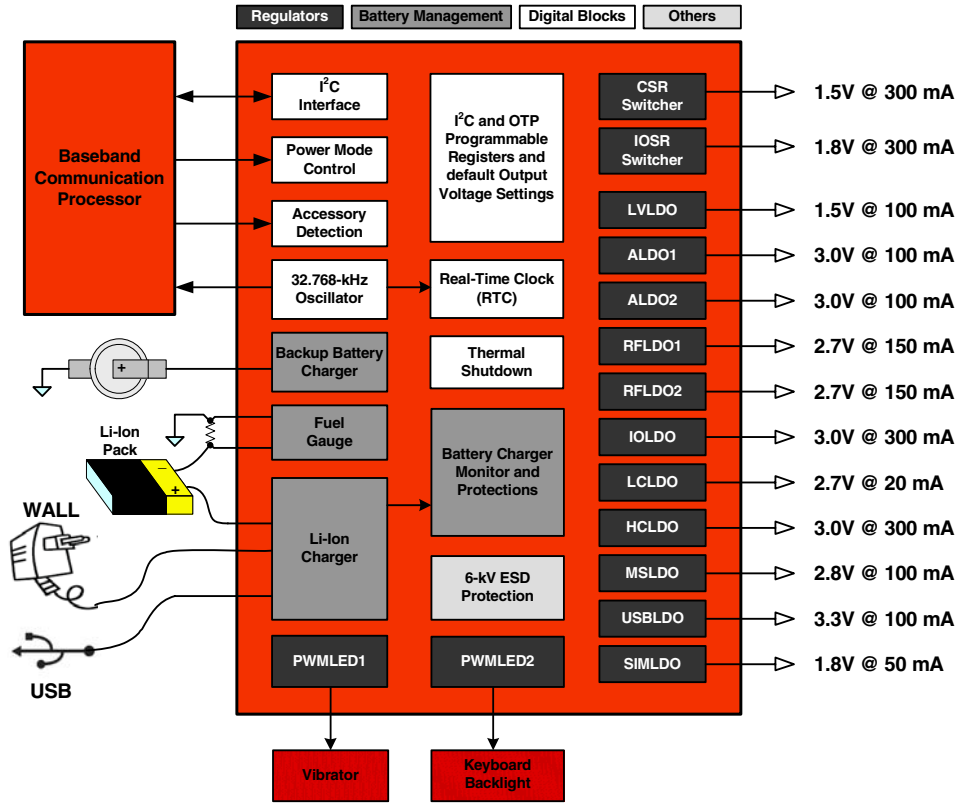

Functional Block Diagram

The BCM59001 is a highly integrated and complete power management solution specifically designed for midrange Li-Ion- or Li-Pol-powered mobile handhells.

Power Management

This device implements advanced power management including two highly efficient switching regulators for core and I/O supply and 11 high-performance LDOs with ECO mode. The peak efficiencies of the switching regulators are 93% and ~83% at 1 mA low-power mode. A switching frequency of 2 MHz enables small 2.2- μ H inductors and 4.7- μ F output capacitors. The output voltage of the switching regulators and the LDOs is I²C-programmable in 100-mV steps.

Battery Management

The battery management system has a wide input voltage range of up to 20V to enable operation with inexpensive chargers. It features a CC/CV USB/wall adapter linear charger with automatic charging source detection and a CC/CV mode backup battery charger. This system has extensive protection, monitoring, and safety features such as charger

overvoltage and overcurrent protection on the wall adapter pin and watchdog timer circuit. In addition, the device features accurate USB current limiting, and the highly accurate coulomb counter-based fuel gauge provides precise measurement of the remaining battery voltage.

Controls and Interfaces

The BCM59001 has 100/400-kHz I²C compatible serial interface for communication with the host controller for built-in state machine, on/off control module, interrupt control and monitoring circuits. The aggressive energy management is achieved through additional power control pin interface which controls sleep cycle quiescent current states. PONKY, accessory detection, and hands-free detection supports phone power on/off remote key and headset detections with debounce. Two programmable PWMLED current sources are available to drive vibrator and/or LEDs. RTC provides time reference and alarm functions with wake-up control. Chip features extensive protection and monitoring including overvoltage, overcurrent on chargers and all regulators, thermal shutdown, and 6-kV ESD on use-accessible pins.

Broadcom[®], the pulse logo, Connecting everything[®], and the Connecting everything logo are among the trademarks of Broadcom Corporation and/or its affiliates in the United States, certain other countries and/or the EU. Any other trademarks or trade names mentioned are the property of their respective owners.

Connecting
everything[®]



BROADCOM CORPORATION
16215 Alton Parkway, P.O. Box 57013
Irvine, California 92619-7013

Phone: 949-450-8700
Fax: 949-450-8710
E-mail: info@broadcom.com
Web: www.broadcom.com

© 2006 by BROADCOM CORPORATION. All rights reserved.

59001-PB01-R 11/30/06